

Fiber OPTIC Connector Failures

By Andrew Devine

Published: Connector Specifier October, 2002

Identifying where and why fiber optic connectors fail is the first step in creating a reliable connection. Connector failures are induced during manufacturing, by environmental factors and by improper handling (see Figure 1). All of these failure modes can be avoided with proper design, screening, testing and handling of connectors.

Broken Fiber in the Ferrule

There are three causes of broken fiber in the ferrule — inserting a weak fiber into the ferrule, air voids in the epoxy and uncontrolled epoxy expansion. Some fibers break during the production process, which makes them easy to detect. However, minor damage will not be detected if it does not increase insertion loss or return loss of the connector. This minor damage is the greatest concern because it causes failures in the field.

Fibers are weakened before they are even inserted because of the stripping process or damage to the stripped fiber. All fibers have a buffer, which protects the fiber from moisture. This buffer is stripped off by mechanical strippers, thermal strippers or chemicals such as acid. The fiber is weakened by the stripper nicking the fiber or the chemicals attacking the fiber. Once the fiber is stripped, it is vulnerable to damage from mishandling or moisture.

Epoxy air voids can break the fiber as they expand or contract because of changes in temperature. The worst type of void is one that is on the side of the fiber, causing the fiber to bend and break as temperatures change (see Figure 2). The first process that introduces air voids is the mixing of a two-part epoxy or thawing a frozen epoxy. In either case, the voids are clearly visible. The next process is drawing the epoxy into a syringe and injecting it into the ferrule. The final process is inserting the fiber into the ferrule. During this process, air gets trapped at the transition from the fiber to the buffer or from the buffer to the 900 μm tubing. If loose-tube 900 μm tubing is inserted without curing the epoxy between the tubing and the fiber, the epoxy will be wicked out of the ferrule, thus creating a void.

Uncontrolled epoxy expansion can occur from a poorly chosen ferrule or epoxy. A poorly designed ferrule can trap air voids as the epoxy is injected or allow the epoxy to expand uncontrollably. For instance, a ferrule with a large epoxy-filled cone at the back forces the epoxy and fiber to shift back inside the ferrule as the epoxy expands. A poorly chosen epoxy can expand excessively if the epoxy's coefficient of thermal expansion is too high or if the epoxy's glass transition temperature is below the use temperature of the connector.

These three causes will not be detected during production if the insertion loss or return loss of the connector does not increase. Telcordia testing only requires 21 thermal cycles from -40° to 75°C, which may not be enough thermal cycles to propagate a crack in the fiber causing a failure.

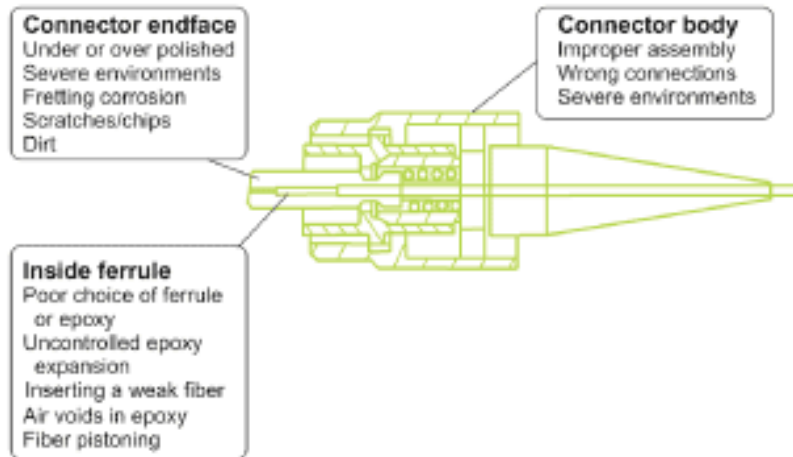

Figure 1. Location and causes of connector failures.

Ferrule Endface Quality

Poor ferrule endface quality includes under or over polishing, chipped fibers and scratched fibers. One advantage of poor endface quality is that it can be easily seen, unlike broken fiber in the ferrule. Another advantage is that all of these conditions are easily detectable and preventable during production. The one exception is that chipped fibers can occasionally appear in the field.

Under and over polished ferrules lead to poor mating of connectors. A ferrule is under polished when it has excessive scratches on it or if it does not meet Telcordia geometry requirements. Telcordia specifies what the ferrule radius, apex offset, fiber height and angle should be. A ferrule is over polished when it becomes too short to make full contact with a mating ferrule.

Chipped fibers are caused mostly by poor cleaving. A fiber is cleaved after inserting it into the ferrule and prior to polishing. Poor cleaving can put stress on the fiber at the end of the ferrule. When the fiber is cleaved, it can break at an angle all the way back inside the ferrule. A chip usually shows up as a rainbow of colors when viewing the fiber through a microscope.

Scratched fibers come from improper polishing, mating and handling of connectors. Improper polishing means that the ferrule was not fully polished, leaving scratches on the fiber, or that the polishing itself put scratches on the fiber. Scratches caused by mating of connectors are the result of hitting the ferrule endface of the connector against the adapter. Dropping the connector or hitting it against an object also causes scratches on the fiber.

Improper Connector Bodies

Connector bodies fail from improper assembly or from damage caused by severe environments. Connectors such as SC and FC connectors can consist of five to 12 parts. If all of these parts are not put into a connector body correctly, the connector cannot function properly. Excess epoxy can also prevent proper functioning of the connector by flowing into the connector body, preventing the ferrule from springing back.

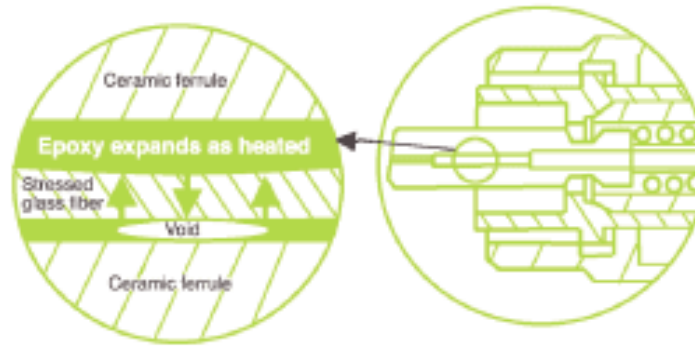

Figure 2. Stress on a fiber caused by an air void and epoxy expansion.

Damage to connectors in severe environments usually occurs from extreme vibration, shock or temperatures. Connector bodies that are used in these environments should be tested to ensure they can withstand the elements.

Adapters, which are used to mate connectors together, can contribute to failures with broken or tight-fitting sleeves. The sleeves within an adapter must be free floating to allow the ferrules to mate and align.

Environmentally Induced Failure Modes

Fiber pistoning refers to the fiber moving within the ferrule during thermal cycling. As the mated connector and adapter are heated, they move and expand relative to each other except for the two mating surfaces of the fibers, which press against each other. This forces the ferrule to expand forward on the fiber. As the ferrule and fiber cool, the ferrule constricts around the fiber and pulls it back. Over tens or hundreds of lifecycles, the fibers slowly move apart.

Ferrule endface damage occurs during vibration. As the interconnection vibrates, the two ferrule endfaces vibrate against each other causing scratches and damage to the surface of the fiber. Fretting corrosion has been observed on metal ferrules subject to vibration.

Dropouts are short time periods, such as one hundredth of a second, where no data is transmitted through a connector. Dropouts occur during extreme vibration or shock, such as an airplane taking off or landing.

Handling Induced Failure Modes

Assembling connectors without proper cleaning can leave dirt that blocks the signal. A speck of dust one tenth the diameter of a human hair left on the fiber core of a singlemode connector will completely block the signal. Cleaning connectors in a lab or production environment is relatively easy. The challenge is mating a connector for an airplane on the flight line with dust everywhere.

The most common way to scratch a connector during use is to touch the ferrule endface of the connector to the adapter when inserting it. A connector is also scratched by cleaning it with a dirty wipe or simply dropping or hitting the connector against an object.

Improper matings occur when incompatible connectors or adapters are used. Incompatible connections can occur when someone simply tries to insert FC connectors with a wide key into FC adapters with narrow slots. There are actually four different standards for the width of the key and slot on FC connectors and adapters.

Conclusion

Many conditions can lead to a fiber optic connector failing. However, each one of these failure modes can be avoided with proper design, screening, testing and handling of connectors. To avoid these failures, companies should ask whoever builds their connectors if they have looked at these failure modes and what they are doing to prevent them.

ANDREW DEVINE is President of Coastal Connections, 2368 Eastman Ave., Ventura, CA 93003; (805) 644-5051 Fax: (805) 644-5355; E-mail: andy@coastalcon.com; Web site: www.coastalcon.com.

SPEC SHEET

End Applications:

Telecommunications

Related Products:

Fiber optic connectors, ferrules, epoxies

Main Point:

Many conditions can lead to fiber optic connector failure. These conditions occur during manufacturing or because of environmental or handling factors. Examples include broken fiber in the ferrule, poor ferrule endface quality, scratched connectors and improper mating. Each of these can be avoided with proper design, screening, testing and handling of connectors.